

GROUNDWATER REMEDIATION

Total Fluids Recovery

Pumps

Controllers

Accessories

Hydrocarbon Recovery

Guide to Product Recovery

LNAPL Recovery (Floating Product)

Controllers

Accessories

Hydrocarbon Recovery - DNAPL (Sinking Product)

Air Stripper

Miscellaneous Remediation

SUBMERSIBLE PUMP GUIDE:

The Pump Wizard is a powerful tool that lets you investigate how your site's pumping conditions impact your choice of submersible pumps.

Try it at: www.submersiblepumpguide.com

QED AutoPumps - AP3 & AP2

AutoPumps were designed specifically to handle difficult conditions reliably and safely, including hydrocarbon (LNAPL and dissolved phase) remediation, landfill leachate and methane condensate pumping, solvent (dissolved phase and DNAPL) cleanup, suspended solids, silts, corrosives and high viscosities, along with high temperatures and frequent starts and stops.

Air-powered AutoPumps are proven worldwide at thousands of remediation and landfill sites, which is why AutoPumps are the No. 1 choice of professionals based on reliability, durability, performance range and technical support.

The superiority of the AutoPump design is based on four key strengths

- High clearance fluid pathways
- Using air as the motive force
- Materials of construction matched to site conditions
- A simple yet rugged operating mechanism

Unlike electric pumps, air-powered AutoPumps use no high-speed motors, bearings or impellers, so AutoPumps don't heat up, seize up or get ground up. AutoPumps do not agitate the liquid which is typical of electric pumps. Air-powered also means eliminating the dangers and costs of electricity at and in the well.

AutoPumps actually have a built-in

control system - they pump when there is liquid present and shut down when the level is drawn down, without the need for any sensors in the well or controls at the surface.

How it works

AutoPumps are air-powered positive displacement pumps that require no surface timer-based controllers, bubblers or sensors in the well to operate. The pump is activated by an internal float in response to the natural well recharge. Because the AutoPumps fill by gravity and discharge by air displacement, no emulsification is created during its operation.

Fill Cycle

The fluid pushes the inlet check-valve open and fluid enters the pump. As the fluid level rises, air is expelled through the exhaust air valve and the internal float rises to the top of its stroke.

In this upper position, the float triggers a lever assembly, which closes the air exhaust valve and opens the air inlet allowing air to enter and pressurise the pump.

Discharge Cycle

With the air inlet open, air pressure builds up within the pump body. This causes the fluid inlet check-valve to close and forces the fluid to be displaced up and out of the fluid outlet.

As the fluid level falls, the float



moves downward to the bottom of its stroke.

In this lower position, the float triggers the lever assembly to close the air supply and open the air exhaust valve. And a new cycle begins.

Ordering Information

Select

- 2" or 3" diameter
- Bottom or Top loading
- Long or short pump
- Fittings: brass or SS, barbed or QC



AutoPump Model	Inlet Position	Outside Dia. (cm)	Overall Length (cm)	Max Flow (Lpm)	Max Depth (m)	Actuation Level (cm)
AP3B Long	Bottom	6.68 cm	132 cm	27.6 Lpm	67 m	79 cm
AP3B Short	Bottom	6.68 cm	107 cm	22.7 Lpm	53.3 m	56 cm
AP3T Long	Top	8.64 cm	145 cm	20 Lpm	67 m	135 cm
AP3T Short	Top	8.64 cm	119 cm	18.1 Lpm	53.3 m	107 cm
AP2B Long	Bottom	4.45 cm	139 cm	8.82 Lpm	91.4 m	88.9 cm
AP2B Short	Bottom	4.45 cm	85 cm	7.57 Lpm	91.4 m	51 cm
AP2T Long	Top	4.45 cm	145 cm	7.2 Lpm	91.4 m	132 cm
AP2T Short	Top	4.45 cm	89 cm	6.0 Lpm	91.4 m	77.2 cm

For Filter Regulators & Pulse Counters
See page 190



For Well Caps
See page 189



QED AP4+ Autopump®

The Next Generation AutoPump

Easier to Disassemble and Clean

The AP4+ was made easier to clean by borrowing from our HammerHead® pump design, using 3 bolts to attach the pump inlet and open up the pump. This is easier than having to rotate the inlet multiple turns to unthread it from the center tube inside the pump, especially under field conditions of silt, deposits and coatings. Removing the inlet is also aided by the new, precision ID pump casing, ensuring a more controlled fit. The new pump casing's smoother internal surface has the added benefit of reducing the rate of buildup of solids and coatings inside in some cases. The Easy Fittings make it a snap to remove the tubing from the pump without cutting, and the float is now easily removed by pulling a clip.

Upgraded Materials

The new AP4+ features upgraded materials for many parts to further extend the service life of the pump and to broaden the range of conditions each model can be used in. All nonmetallic internal parts are now made of PVDF*; this is a high-grade engineering plastic with higher strength at elevated temperatures and extremely broad chemical resistance, including to acidic and oxidizing cleaning agents sometimes used for pump maintenance. All stainless steel parts have been upgraded to 304 grade or higher for improved corrosion resistance.

Expanded 5-year Warranty

The new and improved warranty, a straight 5-year warranty with no pro-rating, is proof of the AP4+'s successful history and continued improvements.

Of course, the new AP4+ is compatible with the AutoPump Family of

Accessories, including:

- Sheathed nylon pump tubing sets for maximum chemical resistance, reduced weight, less tangling and easier handling, another innovation lead by QED.
- QED's Easy Fittings for affordable, quick connection and removal of the pump from its tubing set, built to function easily even under high solids well conditions. These are now available pre-installed to pump and tubing so pump system installation just snaps together!
- QED's Easy Bolts for rapid access to flanged wellheads.
- The industry's widest range of wellhead completions to match your site so that pump installation goes smoothly. Custom options are available to fit your specific wellhead requirements.

*Except for the standard top-filling wye, which is made of acetal.

Specifications

AP4+ Model	Inlet Position	Outside dia. (cm)	Overall length (cm)	Max flow (L/min)	Max depth (m)	Actuation level (cm)
AP4+B Long	Bottom	9.1	51.4	69	76	98
AP4+B Short	Bottom	9.1	100	49	76	68
AP4+B Low Drawdown	Bottom	9.1	70	26.5	76	39
AP4+B Long	Top	9.1	144	38	76	135
AP4+B Short	Top	9.1	110	34	76	106
AP4+B Low Drawdown	Top	9.1	78	24	76	70



Leachate Knock-Out Pot

Landfill Gas (LFG) is saturated with water vapor. As the gas cools in the extraction system piping, the vapor condenses into droplets that become entrained in the gas flow. Eventually, the droplets combine and pool as LFG condensate. Accumulations of condensate in LFG pipelines can obstruct and in some cases, completely block gas flow. This can lead to surging in the gas lines, making extraction system control and tuning difficult. Therefore, LFG condensate must be removed in a controlled manner. In cases where environmental regulations prohibit the return of condensate to the landfill, the Knock-Out (KO) Pump System plays an integral role in achieving regulatory compliance.

Key Benefits

- Completely prefabricated and factory tested
- Easily installed and maintained
- Safe and reliable pneumatic or electric design
- Quick-connect fittings
- Durable Polyethylene or PVC construction
- Corrosion resistant components

Knock-Out in-line Design Simplifies Installations

The KO system is designed to be installed in-line with the LFG pipelines, with its inlet and outlet attaching to a straight or sloping pipeline segment. Deep excavations for waste removal and numerous elevation changes required for saw tooth or low-point collection systems are eliminated. The KO incorporates tough, corrosion resistant materials and components proven reliable in harsh landfill applications. The pneumatic AutoPump and controls provide safety and reliability in the harsh and explosive environment of a landfill.

Automatic Operation Reduces Costs

Gas velocity moves the stream of entrained moisture through the pipeline and into the KO unit where the condensate is separated from the LFG stream using a cyclonic separation process. Elimination of direct impact reduces pressure drop.

While LFG exits the outlet pipe, the condensate is temporarily held in the intermediate transfer reservoir. A pneumatic AutoPump and level controller mounted directly above the reservoir, automatically discharges the condensate to an appropriate point of disposal-eliminating the costs of daily checking and manually pumping individual traps, low spots and other collection points.



KO Inlet/Outlet Size	Flow Rate (SCFM)	Pressure Drop (Inches H ₂ O)
200mm (8")	1140	2.0
250mm (10")	1700	1.9
300mm (12")	2400	2.1
350mm (14")	2400	1.9

Type	Max. Flow	Max. Discharge Head
Pneumatic Submersible	30 lpm	61m

QED Pulse Pump

Cleanup well conditions can be extremely hostile: powerful solvents, gasoline and fuel oil, strong acids, caustic bases, corrosive chlorides. That's why QED makes the Pulse Pump series (our basic gas displacement pumps) in a variety of proven materials that won't just survive, but will deliver years of trouble-free performance.

Every Pulse Pump model has only two moving parts downwell and high-clearance, self-cleaning ball check valves. This simplicity keeps them working when high solids, viscosity, or chemical attack cause other pumps to clog or breakdown. An external controller is required to control the alternating pressurisation and venting cycles for the pump.

The Pulse Pump design is especially suited for sinking hydrocarbons (DNAPL) recovery, which is often complicated by high viscosity and/or extremely aggressive solvents.

Intrinsically safe Pulse Pump systems are fast and easy to install,

with no electrical connections at the wellhead.

Flow optimisation is simple too; rugged, dependable pumps and controllers (the solar/AC powered C100M and the all-pneumatic L360) deliver reliable operation without needing frequent attention or repair.

Suitable for harsh environments, including the most demanding ground water cleanup, leachate collection and sinking layer recovery applications.

How it works

The Pulse Pump is air-powered and requires an external timer-based controller to control the air cycling OFF and ON to the pump. The external controller provides alternating cycles of venting to allow the pump to fill, and pressurising to discharge the liquid from the pump. The pump fills through the intake check valve during the refill portion of the cycle, while the pump discharge check valve is sealed. When the external controller applies compressed air



to the pump during the discharge cycle, the intake check valve seals and the discharge check valve opens, sending the liquid into the discharge tube to the wellhead. The cycles are then repeated.

The controller options for Pulse Pumps include:

- The all-pneumatic L360, with settable refill and discharge times to match site conditions. The L360 cycle controller can be coupled with the L370 level controller to stop pump operation when liquid levels fall below the set point.
- The C100M electronic controller, which can be powered by its built-in solar panel or the included AC adapter. The C100M provides lots of flexibility in cycle times and settable "Off" periods, as well as economical low liquid level shutoff and tank-full float switches. The AC power source is required for continuous pump operation.

Ordering Information

Select

- Pulse Pump Model
- Material
- Choose controller

For Well Caps
See page 189



Controller to suit
See page 187-188

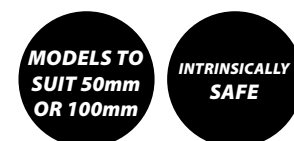

	LP1301	LP1401	LP1001	LP4600
Inlet	Bottom	Bottom	Bottom	Bottom
Outside Diameter	42 mm	32 mm	73 mm	73 mm
Length	51 cm	51 cm	39.4 cm	126 cm
Weight	0.9 Kg	0.7 Kg	1.4 Kg	3.6 Kg
Materials	Stainless steel, PTFE	Brass	PVC	PVC
Fittings: Type/Materials	Compression/SS	Barb/Brass	Compression/Nylon	Barb/Nylon
Sizes: Liquid Discharge	13 mm (1/2in)	13 mm (1/2in)	19 mm (3/4in)	19 mm (3/4in)
Air Supply	9 mm (3/8in)	9 mm (3/8in)	13 mm (1/2in)	13 mm (1/2in)
Pump Stroke	350 mL	300 mL	650 mL	2,000 mL
Operating Pressure Range	40-100 psi	40-100 psi	40-100 psi	40-100 psi
Maximum Lift	70 m	70 m	70 m	70 m
Maximum Flow Rate	7.5 Lpm 10,900 Lpd	6.8 Lpm 9,810 Lpd	11.4 Lpm 16,350 Lpd	28 Lpm 40,800 Lpd
Minimum Submergence	< 30 cm	< 30 cm	< 30 cm	< 30 cm
Density of Pumped Liquid	Any	Any	Any	Any
Cap Sizes	50, 100, 125, 150 and 200 mm	50, 100, 125, 150 and 200 mm	50, 100, 125, 150 and 200 mm	50, 100, 125, 150 and 200 mm

QED Slider™ Pump

Designed for angled wells 20° to 90°

The increased availability of special drilling equipment has caused more landfills and cleanup projects to appreciate the unique advantages of low-angle (slanted or horizontal) wells or risers where conventional vertical wells are inefficient or impossible to use.

Sloped landfill risers for leachate and/or landfill gas allow wellhead installations and other equipment to be placed outside landfill cells, not in the middle of them. This protects headers and other equipment and facilitates normal landfill operations. Cleanup projects can also benefit. Narrow water or product layers can often be more efficiently intercepted by a horizontal well. Inaccessible contaminant plumes under buildings or sensitive areas can be reached; the technique is also a cost-cutting alternative to trenches for capturing widespread floating layers.

However, slant/horizontal wells are useless without the right pumps – and typical electric submersible or pneumatic pumps don't operate effectively in low-angle or horizontal installations.

QED Slider™ pumps provide the answer. They have proprietary angle-independent valves to operate at any orientation and can deliver reliable flow, at rates up to 35.9 Lpm/51.7 m3/day in 5in. (125mm) and larger wells. They can also be modified to fit 4in. (100mm) wells. They are especially suited for tough landfill duty, providing excellent resistance to sediment clogging and solvent attack. Slider pumps are operated by QED's standard Pulse Link® Controller Modules.



Ordering Information

Select

- Slider™ Pump Model
- Choose controller



For Well Caps
See page 189 >>>

Controller to suit
See page 187-188 >>>

Slider Pump	SL6000
OD	114mm
Length	175 cm
Weight	13.6 Kg
Materials	Stainless Steel, HDPE, PTFE, Delrin, Viton
Fittings/Sizes	Discharge: Stainless Steel Barb Type for 1-1/4 in. (32 mm) OD Tubing Air Supply: Stainless Steel Compression Type for 5/8 in. (16 mm) OD Tubing
Pump Stroke	5 liters per stroke
Operating Pressure Range	0-100 psi (0-6.9 bar)
Maximum Lift	62 m
Maximum Flow Rate	36 lpm (when pump is vertical) *

**Flow rates for this pump installed on an angle will be 30% of this.*

QED C100M Digital Controller

The C100M Digital Controller can be used to set pump refill and discharge cycle times for the Programmable Genie®, Ferret® and Pulse Pump®.

The C100M is solar-powered, with unique power-saving circuit design and a 10-day battery backup to allow operation even in northern region winter conditions. It is rated as intrinsically safe in solar mode. An AC power adapter is also included for site conditions which prevent solar charging.

The C100M provides easy-to-use digital control of pump discharge and refill cycles. Its programmable OFF time settings make it convenient to adjust daily pumping rates so that maximum LNAPL flow through the soil can be maintained, to enhance long-term recovery rates.

Optional level switches for the C100M provide an economical means for system shutdown when the collection tank is full and/or the well level drops too low.

Key functions

- GOTO** Allows manual toggling of valve and system ON & OFF cycles. Also enabling and disabling of system
- DATA** Multiscreen key to sequentially display well status, battery status, solar panel voltage, ON/OFF and system valve
- TIME** Allows system counts and time sums and valve time settings



C100M Controller	
Control Type	Solar/Electric/Pneumatic
Dimensions	8.9 cm x 9.3 cm x 8.9 cm
Weight	1.4kg
Enclosure Type	Fiber reinforced thermoplastic NEMA 4X and UL 508
Power	SOLAR: Shatterproof solar panel on enclosure top with backup battery pack with 10-day reserve capacity. CSA* compliance, intrinsically safe, class 1, division 1, group C & D**. Optional power converter plugs into 240 VAC outlet and supplies 3VDC (300 milliamp) to connector plug in enclosure bottom. Not rated intrinsically safe when connected to mains power.
Operating Temperature	-28.9 °C to 65.6 °C
Display	TYPE: LCD display with 16 character alphanumeric, temperature compensated contrast, and power OFF control. WINDOW: Non-glare, double hardened optical acrylic.
Pneumatic Control	TYPE: Latching solenoid with dual port manifold. FITTING: Female 1/4-18 in. NPT brass with nickel plating. PRESSURE: 100 psi (6.9 bar) maximum.
Flow Capacity	Sufficient for single Ferret or single Genie. Contact QED for other requirements

- * C100M is rated CSA intrinsically safe when used in solar mode only.
- ** C100M is NOT rated CSA intrinsically safe when used with 110 VAC power converter.

Ordering Information

- QEDC100M** Digital Controller
- QEDCTRFTO** Tank Full Shut-Off Kit, to be used in combination with the Model C100(M) Digital Controller
- QED38110** External solar panel and mounting bracket for C100(M). Use of external panel from QED maintains the intrinsically safe rating of the controller.



*only when used in solar mode

QED Pulse Link Modular Pump Controller

The Pulse link modular control systems operates all Slider, Pulse pumps and Eliminator pumps with options to serve multiple well and level control needs. QED pneumatic control modules are the design forefront in reliability and longevity.

L360 - Pulse Sender / Controller

The L360 Cycle Controller provides a rugged, all-pneumatic control of pump cycle times for the Programmable Genie®, Ferret®, Slider® and Pulse Pump®. The L360 is especially suited to sites where no electronics are allowed, or where pump cycle rates exceed the limits of the C100M in solar mode.

The L370 Level Mate can be used with the L360 to shut off the system when the well level drops below the set point.

L370 - Level Mate

L370 Level Mate is used with a Pulse Sender module in multiple well systems, where independent on/off level control is required for more than one well. Each L370 controls one well and has its own bubbler line to sense liquid level. This makes it possible to fine tune individual wells that differ significantly in recovery rate.



Ordering Information	
QEDL360	Pulse Sender Includes: pressure regulator and gauge
QEDL370	Level Mate liquid level control module. Used in combination with one Pulse Sender.

Slider Pump - page 186
Pulse Pump - page 207
Eliminator - page 208 >>>



	L360 Pulse Sender	L370 Level Mate
Dimensions	15.4 cm x 10.7 cm x 17.8 cm	15.4 cm x 10.7 cm x 13.3 cm
Weight	2.7 kg	1.8 kg
Operating Pressure	40-100 psi (275-700 kPa)	40-100 psi (275-700 kPa)
Maximum Free Air Flow	7 scfm (12 m3/h)	N/A

Well Caps

Hundreds of wellhead cap and flange combinations are available from QED on a standard and custom basis to fit site needs and ease installation and maintenance. The table below lists some of the most commonly chosen wellhead assemblies.

As well as connecting to the pump tubing or hose, wellhead assemblies have to be designed for safety, equipment support strength, pump level adjustment, access for data and sample collection and durability.



Compression fitting for pass-through hose or tubing.



Quick connect fitting available in brass or stainless steel.



Barb fittings on slip cap (no vacuum).
Barb fitting available in brass or stainless steel.



Ordering Information

Select

- Type of cap
- Fittings
- Fitting material
- Diameter

Wellhead Assembly	Description	Fitting Types	Fitting Materials	Well Diameters
Open-hole cap	Non-sealing cap with open pass-through holes for hoses; allows easy pump height adjustment with support rope/cable.	No fittings	N/A	50mm 100mm 150mm
Slip	Non-sealing cap with fittings for connection to air supply and liquid discharge lines.	Barbs, quick-connects, compression fittings	Brass, SS, Poly	50mm 100mm 150mm
Vacuum Seal	Sealing cap with fitting for connection to air supply and liquid discharge lines.	Barbs, quick-connects, compression fittings	Brass, SS, Poly	50mm 100mm 150mm
Flange	Sealing flange with fittings for connection to air supply and liquid discharge lines.	Barbs, quick-connects, compression fittings	Brass, SS, Poly	Custom

QED Easy Bolt

The Easy Bolt provides the function of conventional nuts and bolt sets, but uses a simple lever action instead of wrenches. The Easy Bolt fits through the flange bolt holes and is tightened by simply pushing the cam lever down. Easy Bolts are constructed of high quality stainless steels, with an investment cast lever.

QED's New Easy Bolt lowers the cost of flange installation and removal

- Faster
- No Tools
- No corrosion or galling failures

Do your field crews spend too much time and money on:

- Removing nuts and bolts?
- Sawing and replacing galvanized nuts and bolts that have corroded?
- Sawing and replacing stainless steel nuts and bolts that have galled?

With Easy Bolt, you can forget the saws and wrenches



Nitrile Hose & Jacketed Nylon Tubing

Advantages

- All dimensions of tubes, hoses and fittings are carefully designed and controlled to ensure high flow capacity, easy assembly, high pullout strength and leak-tight connections.
- Innovative jacketed nylon tubing is highly regarded by experienced users for its light-weight, smooth profile and ease of handling.
- Unmatched range of connector fitting options to make installation and maintenance easier and more efficient.

QED offers the choice of nylon tubing and Nitrile hose for down well use and surface runs to fit different project needs. Nylon tubing is lightweight smaller outside diameter and has superior long-term chemical resistance to most compounds. Hose is easier to handle, coil and bend. Other tube and hose material and size options are also available, including color choices to simplify system connection on site. A full range of connection fittings are offered, including quick-connect, barb and compression fittings in a range of materials.



Jacketed Nylon Tubing



Nitrile Hose

QED Easy Fitting

The Easy Fitting is a new type of lower-cost, quick fitting for the AutoPump, designed for severe duty downwell conditions at landfills and remediation sites. The Easy Fitting allows the AutoPump to be quickly disconnected from its tubing and hose sets, eliminating the need to cut the tubing. Constructed of high-quality, stainless

steels the Easy Fitting is designed to function well even with silt and solids present.

The New Easy Fitting from QED lowers the cost of disconnecting & reconnecting tubing when cleaning pumps

- Faster
- No Clamp removal/replacement
- No need to cut the tubing shorter every time a pump is removed for cleaning

Do your field crews spend too much time and money on:

- Cutting tubing from the pump's barbed fittings during pump removal?
- Removing and replacing tubing clamps?
- Precision cutting the air, exhaust and liquid discharge tubing for proper alignment?

With Easy Fitting, tubing cutters and clamps are needed only for the initial installation



Ordering Information

QED3884 Nylon 12 pump jacketed tubing bundle per metre, includes: 1/2" OD air supply tubing, 5/8" OD exhaust tubing, 1" OD discharge tubing

QED3883 Nylon 12 pump jacketed tubing bundle per metre, includes: 1/2" OD air supply tubing, 5/8" OD exhaust tubing, 1 1/4" OD discharge tubing

QED38955 3/8" ID green hose per metre, for pump air supply

QED38954 1/2" ID blue hose per metre, for pump exhaust

QED39037 3/4" ID black hose per metre, for discharge

QED38953 1" ID black hose per metre, for discharge

Filter Regulator

Keep automatic and programmable pumps running right with particle filtration and easy pressure adjustment for longer pump service.

- Used to regulate the air pressure to the pump.
- Filter element keeps solid particles from entering the pump air valve mechanism.
- Automatic condensate drain optimises performance at cold or humid weather sites.



Cycle/Pulse Counter

A pulse counter is used to count the number of cycles a pneumatic pump has performed. Multiplying the number of pulses measured by the pump volume per cycle gives the amount of liquid pumped in that time period. This provides an accurate method to record how much contaminated water has been pumped for example. The pulse counter goes inline on the air supply hose.



QED Tank Full Shutoff

For the ultimate in safety and reliability, QED offers premium, all-pneumatic tank full shutoff controls in wall-mount (301425) and tank-mount (301426) versions. Both of these field-proven controls use fail-safe and redundant mechanisms to ensure that the pumping system is reliably switched off when the LNAPL or DNAPL collection tank is full.

Method of Operation

The TFSSO System will cease passing compressed air to downstream systems when the recovery tank is full.

The hoses are colour coded and all the fittings are different so only the proper connections can be made.

The TFSSO control includes a two stage filter/regulator. Another filter is provided into the control box for added reliability; this filter also has a visual indicator.



Wall mount shutoff



Tank mount shutoff

Features

- Hoses and tubing are colour coded and all the fittings are different so only the proper connections can be made.
- System operation is simple, straightforward and automatic. Built-in safety features result in operator-free operations even on nights and weekends.
- The TFSSO system can be upgraded to monitor additional recovery tanks.
- The TFSSO system is small and lightweight and can easily be moved from site-to-site.
- The Wall-Mount TFSSO has a three-way valve that allows the operator to shut down the system, exhausting all downstream air without disconnecting hoses or "tripping" the system.
- Rugged construction ensures long system life, even under harsh conditions.
- The entire system is pneumatically powered with no electrical components, thus avoiding sparks in control power and sensing devices.

Ordering Information

- QED301425** Wall mount tank full shut off control box
- QED301426** Tank full shut off, tank mount control box

C100M Level Switch Overfill Protection Device

When high levels are detected, the C100M will discontinue pump operation and will enter and remain in a "Tank Full" and "System Disable" mode; to resume normal operation, the tank level must be lowered sufficiently to deactivate the switch and the C100M must be manually reset.

Once installed, any disconnections or breaks in the switch cable will also cause a "Tank Full" and "System Disable" response.

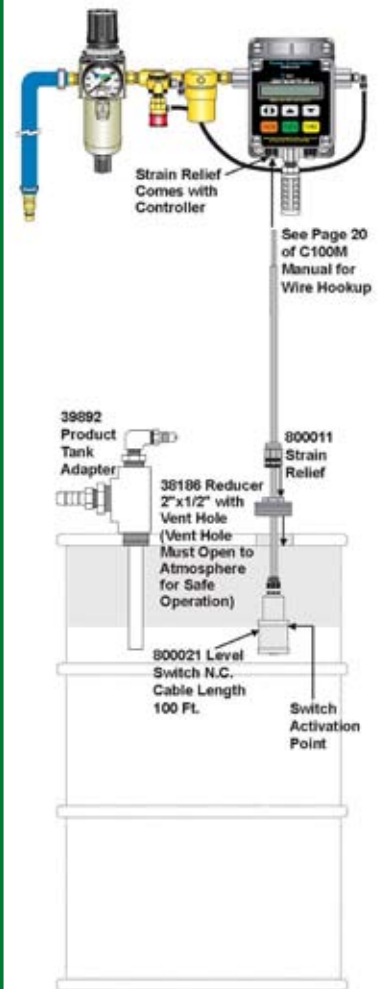

Ordering Information

- QEDCTRLSW** Downwell Pump Level Switch Kit, to be used in combination with the Model C100M Digital Controller
- QEDCTRFTFO** Tank Full Shut-Off Kit, to be used in combination with the Model C100M Digital Controller

**For C100M Controller
See page 205**





What is LNAPL?

The USGS defines light non-aqueous phase liquids as liquids that are sparingly soluble in water and less dense than water. For example, oil is an LNAPL because it “floats” on top of water and does not mix with water. Hydrocarbons, such as oil and gasoline, are examples of LNAPLs.

At LNAPL contaminated sites LNAPL can form a pool in the subsurface on top of the water table.

USGS Website:
<http://toxics.usgs.gov/definitions/lnapls.html>
Accessed 18/08/08

What is DNAPL?

According to the USGS, DNAPL (dense non-aqueous phase liquid) is a liquid that is denser than water and does not dissolve or mix easily in water (it is immiscible).

In the presence of water it forms a separate phase from the water. Many chlorinated solvents, such as trichloroethylene, are DNAPLs.

USGS Website:
http://toxics.usgs.gov/definitions/dnapl_def.html
Accessed 18/08/08

Equipment Selection Guidelines

Selecting the best equipment for LNAPL and DNAPL source reduction depends on matching it to the site conditions and project goals.

The major factors to consider are:

What are the project goals and constraints?

- Importance of pumping LNAPL or DNAPL only, and not water
- Expected duration of project
- Total volume of LNAPL or DNAPL to be removed
- Availability of site labor for service
- Overall budget

Does everything fit into the well?

Equipment selection depends on well diameter, well depth, depth to water and its fluctuation and LNAPL or DNAPL layer thickness.

What's being removed?

The type of fuel or solvent, its viscosity, density, temperature, age of spill and the presence of biological growth or debris affect equipment performance.

What LNAPL or DNAPL removal rate is needed?

The hydraulic conductivity of the formation, the LNAPL or DNAPL recovery rate in the wells and the pumping strategy determine the maximum LNAPL or DNAPL flow rate that will be required.

Free-Product Recovery Equipment Application Overview	Passive SOS Skimmer	Passive SPG Skimmer	SOS® AutoGenie™	SPG AutoGenie™	SOS® Programmable Genie® & Controller	SPG Programmable Genie® & Controller	Ferret® Floating Inlet & Controller	Ferret® Fixed Inlet & Controller
Fresh gasoline	✓	✓	✓	✓	✓	✓	✓	✓
Weathered diesel or fouled fuel conditions		✓		✓		✓		
LNAPL target layer thickness <25mm			✓		✓		✓	✓
LNAPL target layer thickness >25mm	✓	✓	✓	✓	✓	✓	✓	✓
Water table fluctuation <300mm	✓	✓	✓	✓	✓	✓	✓	✓
Water table fluctuation >300mm	✓	✓	✓	✓	✓	✓		
Below-grade vault well termination needed			✓	✓				
Water exclusion extremely important							✓	✓
System off-time control important	n/a	n/a			✓	✓	✓	✓
Water column below floating layer <45cm	✓	✓	✓	✓	✓	✓		
No contact of drive air with pumped liquid	n/a	n/a	✓	✓	✓	✓		

Representative Properties of Selected Fluids

Liquid	Specific Gravity	Viscosity
SAE 30W oil	.88-.94 (15.6°C)	9.6-12.9 cSt (98.9°C)
SAE 85W oil	.88-.94 (15.6°C)	11.0 cSt min (98.9°C)
SAE 90W oil	.88-.94 (15.6°C)	14.0-25 cSt min (98.9°C)
Benzene	.899 (0°C)	1.0 cSt (0°C)
	.885 (15.6°C)	.744 cSt (20°C)
Corn Oil	.924 (15.6°C)	28.7 cSt (54.4°C)
		8.6 cSt (100°C)
Creosote	1.04-1.10 (15.6°C)	(15.6°C)
		(54.4°C)
Crude Oil 40	.825 (15.6°C)	9.7 cSt (15.6°C)
Diesel fuel 2D	.82-.95 (15.6°C)	2.0-6.0 cSt (37.8°C)
		1.0-3.97 cSt (54.4°C)
Diesel fuel 5D	.82-.95 (15.6°C)	86.6 cSt max (50°C)
		35.2 cSt max (71.1°C)
Fuel Oil #2	.82-.95 (15.6°C)	3.0-7.4 cSt (21.1°C)
		2.11-4.28 cSt (37.8°C)
Fuel Oil #3	.82-.95 (15.6°C)	2.69-5.84 cSt (21.1°C)
		2.06-3.97 cSt (37.8°C)
Fuel Oil #6	.82-.95 (15.6°C)	97.4-660 cSt (50°C)
		37.5-172 cSt (71.1°C)
Gasoline	.72 (15.6°C)	.64 cSt (15.6°C)
Honey		73.6 cSt (37.8°C)
Cutting Oil		40.0-46 cSt (37.8°C)
		23.0-26 cSt (54.4°C)
Kerosene	.78-.82 (15.6°C)	2.71 cSt (20°C)
Jet Fuel	.82 (15.6°C)	7.9 cSt (-34.4°C)
Molasses	1.40-1.46 (15.6°C)	281-5070 cSt (37.8°C)
Naphthalene	1.145 (20°C)	.9 cSt (80°C)
Olive Oil	.91-.92 (15.6°C)	43.2 cSt (37.8°C)
		24.1 cSt (54.4°C)
Pine Tar	1.06 (15.6°C)	559 cSt (37.8°C)
Turpentine	.86-.87 (15.6°C)	86.6-95.2 cSt (37.8°C)
Fresh Water	1.0 (15.6°C)	1.13 cSt (15.6°C)
		.55 cSt (54.4°C)
Whale Oil	.925 (15.6°C)	35.0-39.6 cSt (37.8°C)
		19.9-23.4 cSt (54.4°C)

Based on material from the Hydraulic Institute with additions by Ingersoll-Rand

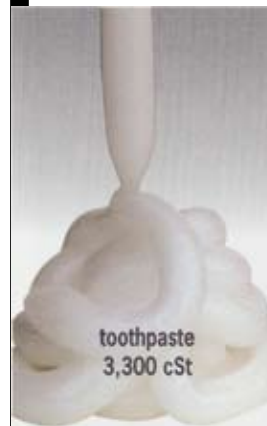

QED Passive Skimmers

The QED family of Passive Skimmers have been designed for product only (LNAPL) recovery applications in sites where active pumping systems are not applicable due to existing conditions or extreme low permeable formations. The floating intake head follows the groundwater fluctuations in the recovery well, allowing only the free-floating phase (LNAPL) to be captured, without taking water, and stored in the built-in reservoir for further manual transfer to a tank.

Advantages

- Simple systems for extreme low recovery applications
- Choice of floating inlet types

Passive Skimmers are available for 2in. (50mm) and 4in. (100mm) extraction wells, with different reservoir capacities.

How it works

Specific gravity and viscosity are two of the most important properties of hydrocarbons (LNAPL) as far as their mobility in the subsurface. At the same time that these parameters affect the migration of the plume, they also play a very important role in the selection of the right skimmer for the cleanup application.

SOS Inlet

The SOS inlet uses a float with an inlet port inside a hydrophobic, or water-rejecting screen. The hydrophobic screen prevents water from being taken in and pumped to the surface, even if the float occasionally sticks or drags as the liquid level fluctuates. The SOS inlet screen is subject to plugging due to potential debris or slimes present in the well, therefore the SOS inlet works best on fresh gasoline and jet fuel spills and less so on weathered diesel.



Item Code	Cannister Volume	Well Diameter	Travel Range	Overall Length
QED301079	600 cc	50mm (2 in.)	30 cm	165 cm
QED301080	900 cc	50mm (2 in.)	30 cm	196 cm
QED301032	3,000 cc	100mm (4 in.)	46 cm	173 cm
QED301033	6,000 cc	100mm (4 in.)	46 cm	216 cm

Ordering Information

- QED301079** SOS2 Passive Skimmer, 600cc, 30cm travel for 50mm wells
- QED301080** SOS2 Passive Skimmer, 900cc, 30cm travel for 50mm wells
- QED301032** SOS4 Passive Skimmer, 3000cc, 46cm travel, for 100mm wells and larger
- QED301033** SOS4 Passive Skimmer, 6000cc, stainless steel, 46cm travel, for 100mm and larger wells

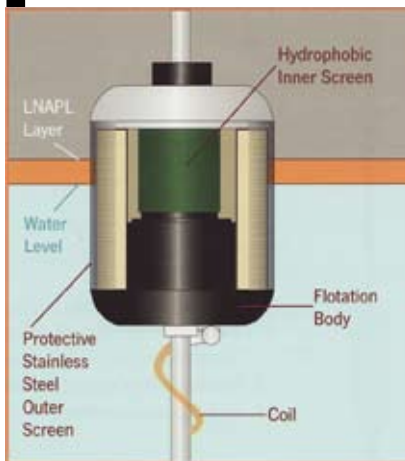

KLEER Skimmers

KLEER® gasoline/diesel skimmers utilise a patented membrane material to separate fuel from water. Subsurface fuel spills are recovered by membrane separation; the fuel simply falls into the passive “bailer” reservoir. These fuel bailers recover gasoline from groundwater and recover diesel from groundwater.

For subsurface diesel spill clean-up and gasoline spill cleanup from groundwater, use the KLEER® membrane fuel bailer. They can be used equally well for groundwater monitoring and remediation.

Our passive skimmers have many advantages that optimise hydrocarbon removal

- Removal of floating hydrocarbon using advanced membrane technology
- They require no power, no moving parts
- Skimmer floats when empty
- Excellent for contaminant drawdown calculations; they require no maintenance

Operation

Remedial support skimmers remove gasoline and diesel from water using a filter membrane located under the slotted filter chamber near the top of your skimmer. Our three standard skimmers are designed to float, when empty, with a part of the filter chamber at the fluid surface. As the skimmer fills it will sink lower. You should limit the distance the skimmer can sink by setting the cable length to a distance demanded by your current fuel and water levels. If the fluid elevation changes, simply adjust the cable so that some of the slots in the chamber contact gasoline/diesel.

To operate most efficiently the fuel/water interface should be at the lower end of the slotted filter to allow as much hydrocarbon as possible to cover the slotted section. The filter is designed to recover a fuel layer of any thickness floating on water when it touches the slotted filter. The KLEER® reservoir is always below the fluid surface; ensure that you have sufficient depth of total fluids to accommodate the length of your reservoir.



Ordering Information
SRMRSS25 Kleer Passive Skimmer
 42mm OD, 0.5 L capacity,
 min water depth 0.9m

PetroPore Passive Skimmer

It floats!

The PetroPore Skimmer is an easy to install and reliable passive skimmer.

The skimmer floats at the product interface, which means that the user does not need to be set to specific depth.

Typical filtration rate 2ml per min in 3mm product thickness.

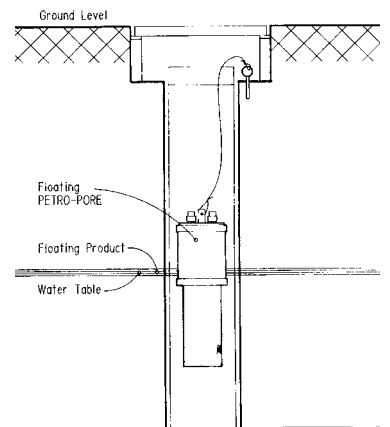

Ordering Information
PIPM300 PetroPore 300, 43mm dia.
 300ml capacity
PIPM750 PetroPore 750, 72mm dia.
 750ml capacity

For standard hydrocarbon bailers See page 32



Skimming Sock Oil Only Absorbent Socks

Tubular absorbent sock that repels water but absorbs oils and petrochemicals for use in monitoring wells 50mm diameter. The main application of the Monitoring Well Skimming Sock is to skim oil out of monitoring wells. Sized to fit into monitoring wells, is easy to remove and absorbs approx 500ml of oil from the well.



Ordering Information
MTHSKM401 Absorbent Sock Monitor Well, oil only, 40x460 mm
 Sold individually or box of 30

QED AutoGenie Internal Controller

Genie skimmers are safe, reliable and complete systems for removing floating LNAPL layers from wells.

Advantages

- Specialised bladder pump is extremely durable, provides high suction to maintain flow and eliminate contact of drive air with pumped fluid.
- Choice of two types of selective floating inlets.
- Continuous Automatic cycling.
- Available in several different lengths and diameters to accommodate specific well conditions.
- Low air consumption.

The SPG and SOS AutoGenie skimmers are air-operated selective LNAPL removal systems with a high suction pump and a floating inlet designed to follow the LNAPL layer as the groundwater level fluctuates. The SPG version uses a specific gravity float and the SOS version uses a hydrophobic screen to exclude water.

All Genie skimmer systems pump the LNAPL using a special bladder pump with high suction capability, positioned above the floating inlet section of the system. The use of a bladder pump eliminates air contact with the LNAPL fluids, minimising emulsification and eliminating VOC emissions.

The AutoGenie uses an integral pneumatic timer to control the pump fill and discharge times. A complete line of matched accessories is available to help with installation and performance, including in-well tubing, well caps, ON/OFF timers, LNAPL collection tank full shutoffs and other items.



How it works

The LNAPL enters the skimmer system through the floating inlet, flows down through a flexible tube, then is pulled upward by the pump's suction action during the fill cycle.

During the discharge cycle, the bladder is squeezed by the compressed air and the LNAPL is pumped to the collection system at the ground surface. Then, during the fill cycle, the compressed air around the bladder is exhausted again and the bladder expands, resuming its original shape. This pulls fluid into the bladder through the check valve at the bottom of the pump.

SPG Inlet

The SPG (specific gravity) inlet uses a float with a controlled specific gravity that causes it to float on water but not in the LNAPL. The SPG float has its fluid inlet port positioned near the top so that it is always above water. If the LNAPL layer gets too thin, the SPG inlet will also be above the LNAPL layer and cease recovery of hydrocarbons until more enters the well.

To accommodate a range of final LNAPL layer thickness, the SPG float has multiple, variable inlet ports that can be opened or plugged to adjust the level of the inlet port.

Why isn't the SPG always set for the thinnest possible LNAPL layer?

The reason is that any float in a small diameter well has a tendency to occasionally stick as liquid levels move up and down, so setting the inlet port too low increases the chance of allowing water to be pumped instead of pumping only LNAPL. So, a trade-off must be made between achieving desired final LNAPL layer thickness and prevention of pumping water.

SOS Inlet

The SOS inlet uses a float with an inlet port inside a hydrophobic, or water-rejecting screen. The hydrophobic screen prevents water from being taken in and pumped to the surface, even if the float occasionally sticks or drags as the liquid level fluctuates. While this is a distinct advantage of the SOS inlet over the SPG type, the SOS inlet screen is more subject to plugging due to potential debris or slimes present in the well. The SOS inlet works best on fresh gasoline and less so on weathered diesel.

Choose the most economical system

***1-3 wells: AutoGenie
4+ wells: Programmable Genie
& controller***

***Programmable Genie
See page 200***



SPG Skimmer Inlet

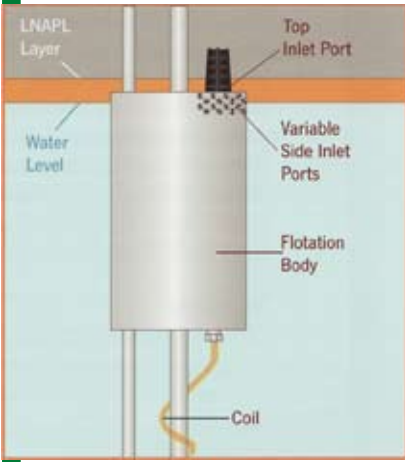

SOS Skimmer Inlet

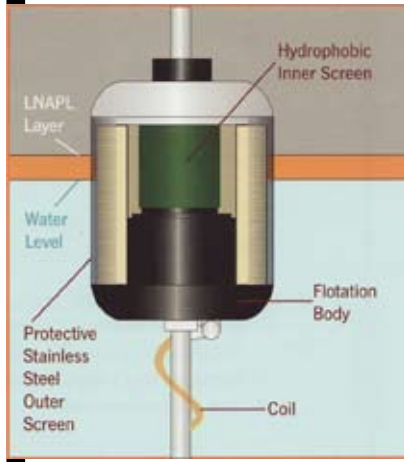

Model No	Genie Pump Item Code	Skimmer Item Code	Maximum LNAPL Recovery Rate	Float Range	Overall Length	Minimum Liquid Column	Minimum Well ID	Maximum OD	Maximum Depth
50mm SPG AutoGenie™**									
AG2415 SPG2	QED300011	QED300440	605 Lpd	38 cm	241 cm	15 cm	50mm	4.75 cm	45.7 m
AG2424 SPG2	QED300011	QED300592	605 Lpd	61 cm	267 cm	30 cm	50mm	4.75 cm	45.7 m
AG2445 SPG2	QED300011	QED300747	605 Lpd	114 cm	330 cm	38 cm	50mm	4.75 cm	45.7 m
AG4815 SPG2	QED301288	QED300440	1,211 Lpd	38 cm	300 cm	15 cm	50mm	4.75 cm	45.7 m
AG4824 SPG2	QED301288	QED300592	1,211 Lpd	61 cm	328 cm	30 cm	50mm	4.75 cm	45.7 m
AG4845 SPG2	QED301288	QED300747	1,211 Lpd	114 cm	389 cm	38 cm	50mm	4.75 cm	45.7 m
100mm SPG AutoGenie™									
AG2424L SPG4	QED300011	QED302522	605 Lpd	61 cm	315 cm	79 cm	100mm	9.63 cm	60.9 m
AG2424C SPG4	QED300011	QED301226	605 Lpd	61 cm	277 cm	38 cm	100mm	9.63 cm	60.9 m
AG2445 SPG4	QED300011	QED300728	605 Lpd	114 cm	329 cm	38 cm	100mm	9.63 cm	60.9 m
AG2460 SPG4	QED300011	QED300523	605 Lpd	152 cm	368 cm	41 cm	100mm	9.63 cm	60.9 m
AG4824L SPG4	QED301288	QED302522	1,211 Lpd	61 cm	376 cm	79 cm	100mm	9.63 cm	60.9 m
AG4824C SPG4	QED301288	QED301226	1,211 Lpd	61 cm	338 cm	38 cm	100mm	9.63 cm	60.9 m
AG4845 SPG4	QED301288	QED300728	1,211 Lpd	114 cm	389 cm	38 cm	100mm	9.63 cm	60.9 m
AG4860 SPG4	QED301288	QED302523	1,211 Lpd	152 cm	429 cm	41 cm	100mm	9.63 cm	60.9 m
100mm SOS AutoGenie™									
AG2412 SOS4	QED300011	QED302524	605 Lpd	30 cm	229 cm	13 cm	100mm	9.63 cm	45.7 m
AG2424L SOS4	QED300011	QED300028	605 Lpd	61 cm	318 cm	74 cm	100mm	9.63 cm	45.7 m
AG2424C SOS4	QED300011	QED302525	605 Lpd	61 cm	274 cm	28 cm	100mm	9.63 cm	45.7 m
AG2448 SOS4	QED300011	QED300776	605 Lpd	122 cm	328 cm	28 cm	100mm	9.63 cm	45.7 m
AG4812 SOS4	QED301288	QED302524	1,211 Lpd	30 cm	292 cm	13 cm	100mm	9.63 cm	45.7 m
AG4824L SOS4	QED301288	QED300028	1,211 Lpd	61 cm	378 cm	74 cm	100mm	9.63 cm	45.7 m
AG4824C SOS4	QED301288	QED302525	1,211 Lpd	61 cm	335 cm	28 cm	100mm	9.63 cm	45.7 m
AG4848 SOS4	QED301288	QED300776	1,211 Lpd	122 cm	389 cm	28 cm	100mm	9.63 cm	45.7 m

**50mm SOS AutoGenie available as special/custom order

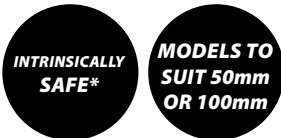

QED Programmable Genie (Formerly known as the PP2 Bladder Pump)

Requires Controller

Genie skimmers are safe, reliable and complete systems for removing floating LNAPL layers from wells.

Advantages

- Programmable cycling.
- Specialised bladder pump is extremely durable, provides high suction to maintain flow and eliminate contact of drive air with pumped fluid.
- Choice of two types of selective floating inlets.
- Available in several different lengths and diameters to accommodate specific well conditions.
- Low air consumption.

The SPG and SOS Programmable Genie skimmers are air-operated selective LNAPL removal systems with a high suction pump and a floating inlet designed to follow the LNAPL layer as the groundwater level fluctuates. The SPG version uses a specific gravity float and the SOS version uses a hydrophobic screen to exclude water.

All Genie skimmer systems pump the LNAPL using a special bladder pump with high suction capability, positioned above the floating inlet section of the system. The use of a bladder pump eliminates air contact with the LNAPL fluids, minimising emulsification and eliminating VOC emissions.

The Programmable Genie uses an electronic controller mounted outside the well to allow adjustment of pump cycles and off times. A complete line of matched accessories is available to help with installation and performance, including in-well tubing, well caps, ON/OFF timers, LNAPL collection tank full shutoffs and other items.



How it works

The LNAPL enters the skimmer system through the floating inlet, flows down through a flexible tube, then is pulled upward by the pump's suction action during the fill cycle. During the discharge cycle, the bladder is squeezed by the compressed air and the LNAPL is pumped to the collection system at the ground surface. Then, during the fill cycle the compressed air around the bladder is exhausted again and the bladder expands, resuming its original shape. This pulls fluid into the bladder through the check valve at the bottom of the pump.

The C100M Digital Controller offers easy and flexible control of skimmer system operation in a compact, solar or AC-powered unit. Touch-pad control and digital display simplify its programming. Programmable Genies utilise the C100M Controller which allows the user to not only control the pump fill/discharge cycles, but also to set OFF periods to match the LNAPL pumping rates to the recovery rates of the well. The C100M includes

an AC power supply for locations where solar power is either not available or insufficient to support high rate pump operation. In solar-powered mode, the C100M is rated intrinsically safe.

SPG Inlet

The SPG (specific gravity) inlet uses a float with a controlled specific gravity that causes it to float on water but not in the LNAPL. The SPG float has its fluid inlet port positioned near the top so that it is always above water. If the LNAPL layer gets too thin, the SPG inlet will also be above the LNAPL layer and cease recovery of hydrocarbons until more enters the well. To accommodate a range of final LNAPL layer thickness, the SPG float has multiple, variable inlet ports that can be opened or plugged to adjust the level of the inlet port.

Why isn't the SPG always set for the thinnest possible LNAPL layer?

The reason is that any float in a small diameter well has a tendency to occasionally stick as liquid levels move up and down, so setting the inlet port too low increases the chance of allowing water to be pumped instead of pumping only LNAPL. So, a trade-off must be made between achieving desired final LNAPL layer thickness and prevention of pumping water.

SOS Inlet

The SOS inlet uses a float with an inlet port inside a hydrophobic, or water-rejecting screen. The hydrophobic screen prevents water from being taken in and pumped to the surface, even if the float occasionally sticks or drags as the liquid level fluctuates. While this is a distinct advantage of the SOS inlet over the SPG type, the SOS inlet screen is more subject to plugging due to potential debris or slimes present in the well. The SOS inlet works best on fresh gasoline and jet fuel spills and less so on weathered diesel.

SPG Skimmer Inlet

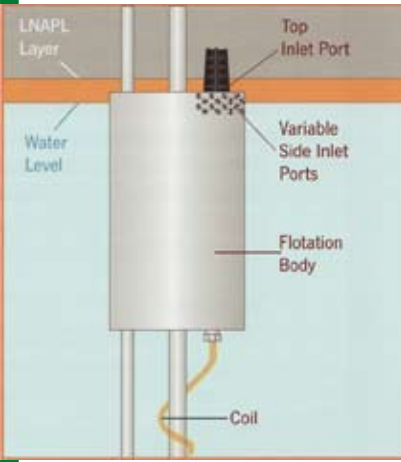

SOS Skimmer Inlet

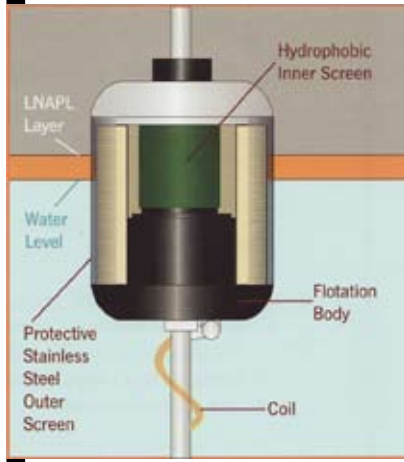

Model No	Genie Pump Item Code	Skimmer Item Code	Maximum LNAPL Recovery Rate	Float Range	Overall Length	Minimum Liquid Column	Minimum Well ID	Maximum OD	Maximum Depth
50mm SPG Programmable Genie®**									
PG2415 SPG2	QED301310	QED300440	605 Lpd	38 cm	213 cm	15 cm	50mm	4.75 cm	45.7 m
PG2424 SPG2	QED301310	QED300592	605 Lpd	61 cm	241 cm	30 cm	50mm	4.75 cm	45.7 m
AG2445 SPG2	QED301310	QED300747	605 Lpd	114 cm	302 cm	38 cm	50mm	4.75 cm	45.7 m
AG4815 SPG2	QED301311	QED300440	1,211 Lpd	38 cm	274 cm	15 cm	50mm	4.75 cm	45.7 m
AG4824 SPG2	QED301311	QED300592	1,211 Lpd	61 cm	305 cm	30 cm	50mm	4.75 cm	45.7 m
AG4845 SPG2	QED301311	QED300747	1,211 Lpd	114 cm	366 cm	38 cm	50mm	4.75 cm	45.7 m
100mm SPG Programmable Genie®									
PG2424L SPG4	QED301310	QED302522	605 Lpd	61 cm	290 cm	79 cm	100mm	9.63 cm	45.7 m
PG2424C SPG4	QED301310	QED301226	605 Lpd	61 cm	251 cm	38 cm	100mm	9.63 cm	45.7 m
PG2445 SPG4	QED301310	QED300728	605 Lpd	114 cm	302 cm	38 cm	100mm	9.63 cm	45.7 m
PG2460 SPG4	QED301310	QED300523	605 Lpd	152 cm	345 cm	41 cm	100mm	9.63 cm	45.7 m
PG4824L SPG4	QED301311	QED302522	1,211 Lpd	61 cm	353 cm	79 cm	100mm	9.63 cm	45.7 m
PG4824C SPG4	QED301311	QED301226	1,211 Lpd	61 cm	312 cm	38 cm	100mm	9.63 cm	45.7 m
PG4845 SPG4	QED301311	QED300728	1,211 Lpd	114 cm	363 cm	38 cm	100mm	9.63 cm	45.7 m
PG4860 SPG4	QED301311	QED302523	1,211 Lpd	152 cm	406 cm	41 cm	100mm	9.63 cm	45.7 m
100mm SOS Programmable Genie®									
PG2412 SOS4	QED301310	QED302524	605 Lpd	30 cm	203 cm	13 cm	100mm	9.63 cm	45.7 m
PG2424L SOS4	QED301310	QED300028	605 Lpd	61 cm	292 cm	74 cm	100mm	9.63 cm	45.7 m
PG2424C SOS4	QED301310	QED302525	605 Lpd	61 cm	249 cm	28 cm	100mm	9.63 cm	45.7 m
PG2448 SOS4	QED301310	QED300776	605 Lpd	122 cm	302 cm	28 cm	100mm	9.63 cm	45.7 m
PG4812 SOS4	QED301311	QED302524	1,211 Lpd	30 cm	267 cm	13 cm	100mm	9.63 cm	45.7 m
PG4824L SOS4	QED301311	QED300028	1,211 Lpd	61 cm	353 cm	74 cm	100mm	9.63 cm	45.7 m
PG4824C SOS4	QED301311	QED302525	1,211 Lpd	61 cm	310 cm	28 cm	100mm	9.63 cm	45.7 m
PG4848 SOS4	QED301311	QED300776	1,211 Lpd	122 cm	363 cm	28 cm	100mm	9.63 cm	45.7 m

**50mm SOS Programmable Genie® available as special/custom order



Choose the most economical system

1-3 wells: AutoGenie
4+ wells: Programable Genie & controller

AutoGenie
See page 198



QED AutoSkimmer™ For High Recovery Wells

The AutoSkimmer Pump System automatically recovers LNAPL layers and pumps on demand when the pump is filled.

Advantages

- High flow, automatic operation for recovery wells with high LNAPL recovery rates.
- Versatile design allows floating inlet removal for conversion to total fluids pumping after the LNAPL later is largely eliminated.
- Air-powered, intrinsically safe.
- Built-in ON/OFF control with internal float.
- Proven reliability and durability.

Combining the industry-leading AutoPump with the rugged SPG floating inlet, the AutoSkimmer delivers higher LNAPL flows for wells with very high floating layer recovery rates. The system can then be switched to even higher flow, total fluids pumping by removing the floating inlet.

When site conditions call for this approach, nothing beats the AutoPump/SPG inlet combination; both of these technologies have been proven in the field for many years around the world.

The AutoPump mechanism means that the pump cycles only when it is filled with LNAPL, reducing air consumption without adding any additional controls or sensors. The SPG inlet includes selectable side inlet ports for versatility in fine-tuning LNAPL intake when the floating layer is reduced in thickness.

How it works

Specific gravity and viscosity are two of the most important properties of hydrocarbons (LNAPL) as far as their mobility in the subsurface. At the same time that these parameters affect the migration of the plume, they also play a very important role in the selection of the right skimmer for the cleanup application.

SPG Inlet

The SPG (specific gravity) inlet uses a float with a controlled specific gravity that causes it to float on water but not in the LNAPL. The SPG float has its fluid inlet port positioned near the top so that it is always above water. If the LNAPL layer gets too thin, the SPG inlet will also be above the LNAPL layer and cease recovery of hydrocarbons until more enters the well.

To accommodate a range of final LNAPL layer thickness, the SPG float has multiple, variable inlet ports

that can be opened or plugged to adjust the level of the inlet port.

Why isn't the SPG always set for the thinnest possible LNAPL layer?

The reason is that any float in a small diameter well has a tendency to occasionally stick as liquid levels move up and down, so setting the inlet port too low increases the chance of allowing water to be pumped instead of pumping only LNAPL. So, a trade-off must be made between achieving desired final LNAPL layer thickness and prevention of pumping water.



	Short AP4-SPG4 Combo Pump
Maximum LNAPL Recovery Rate	1,211 Lpd
Float Range	41 cm
Overall Length	198 cm
Minimum Liquid Column	132 cm
Pressure Range	5-120 psi (0.4-8.5 kg/cm ²)
High Pressure Option	5-120 psi (0.4-8.5 kg/cm ²)
Flow Range	0-0.72 Lpm
Minimum Well ID	10 cm
Maximum OD	8.9 cm
Maximum Depth	60.9 m
Air Supply Pressure (min/max)	40/100 psi (2.7/6.9 bar)
LNAPL Fluid Density	< .85 SG
Kinematic Viscosity	1-1000 cSt
LNAPL Lens Recommended min Starting Thickness	> 7.6 cm
LNAPL Lens Thickness After Skimming	2-7.6 cm
Suitable Types of LNAPL	Gasoline, kerosene, etc.
Materials	Brass, Tygon®, etc.
Fitting Type	Quick-connect, barbs

For Pulse Counters
See page 206



Ferret® In-Well Separator

In-Well Separator

Ferret® In-Well Separators provide an alternative method for reliably and safely removing floating hydrocarbon (LNAPL) layers from water at remediation wells, sumps and tanks. Instead of relying solely on a selective inlet float to avoid pumping water, the Ferret® uses a unique internal separator valve to sense the difference in specific gravity between the hydrocarbon and water, then pumps pure hydrocarbon and rejects any water back into the well.

Advantages

- Unique design uses specific gravity differences to separate LNAPL from water down well.
- For sites with well conditions that hinder proper functioning of hydrophobic screens.
- Available in sizes to fit 2in. and 4in. wells.
- Simple, rugged. Air-powered pump is durable and easy to maintain.
- Programmable, solar-powered controller provides easy flexibility of pumping rates and OFF times to optimise LNAPL recovery rates.



This in-well separation method can be advantageous for well conditions that hinder the performance of hydrophobic screens. Fixed Inlet Ferrets have the best resistance to fouling in difficult wells. All Ferrets use the extremely rugged and simple air displacement pumping principle to pump the LNAPL to the surface and the programmable, solar-powered C100M Controller to select pumping cycle times and system OFF periods to match LNAPL recovery rates.

Ferret models are available in sizes

to fit 2in. and 4in. wells. Models are offered with or without floating inlets to match site needs and user preferences; floating inlets can improve overall LNAPL pumping rates, but the restrictions inherent in floats and tubing coils can hinder LNAPL flow in wells that are highly fouled or have high viscosity fluids.

A complete line of matched accessories is available to help installation and system performance, including in-well tubing, well caps, LNAPL collection tank full shutoffs and other items.

Name	High Capacity with Fixed Inlet	High Capacity with Floating Inlet	Standard with Fixed Inlet	Standard with Floating Inlet
Model No.	HIWS42	HIWSF12	AIWS22	AIWSF12
Overall Length	58 cm	128 cm	76 cm	119 cm
OD	90 cm	90 cm	45 cm	45 cm
Floating Layer Density	0.90 cc	0.90 cc	0.90 cc	0.90 cc
Max Viscosity	1,000 cSt	350 cSt	100 cSt	4 cSt
Min Liquid Depth	46 cm	89 cm	54 cm	89 cm
Inlet type and Range	Stationary	Floating with 31 cm range	Stationary	Floating with 31 cm range
Max Flow Rate*	1137 Lpd with 91 cm LNAPL	0140 Lpd with 30 cm LNAPL	379 Lpd with 30 cm LNAPL	379 Lpd with 30 cm LNAPL
Max LNAPL Volume per Cycle**	1,300 mL if no water taken in	1,300 mL if no water taken in	280 mL if no water taken in	280 mL if no water taken in
Compatible Floating Layer LNAPLs	Gasoline, jet fuel, kerosene, fresh and weathered diesel, #2-#5 fuel oil, light-weight motor oils, and hydraulic fluids			Gasoline, jet fuel, kerosene, fresh diesel fuel, and #2 fuel oil
Materials	Stainless steel, brass, Delrin®, Viton®; Floating inlet models include epoxy float and fuel grade tubing coil.			
Fittings	Brass compression: discharge - 1/2 in. (13 mm); air supply and level gage - 1/4 in. (6 mm)			
Max Lift	200 ft. (61m) @ 120 psi (840 kPa)			
Air Supply Pressure	50-120 psi (350-840 kPa)			
Air Supply Flow	0.5-1.0 scfm (0.85-1.7 m3/hr) flow			

* Rate will vary depending on viscosity, hydrocarbon layer thickness, and site conditions.

**Max. 6 cycles per minute, Minimum 1 cycle per 99hrs.

Ferret Pump - Cont.

HOW THEY WORK

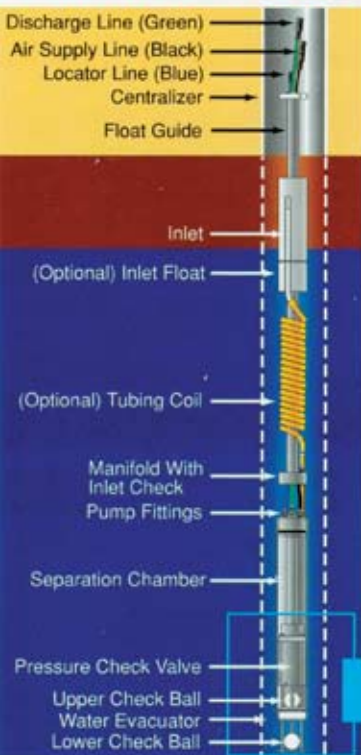

1 Refill Cycle: AIR SUPPLY OFF
Hydrocarbon (red) and/or water (blue) enter the inlet. As the pump fills, water settles to the bottom and hydrocarbon droplets coalesce and float on top. The lower check ball floats and rises, preventing water from entering the bottom of the pump.

2 Water Discharge Cycle: AIR SUPPLY ON
Air pressure forces the lower check ball down, while the upper check ball floats, allowing water to exit the bottom of the pump. Low pressure in the pump keeps the pressure check valve shut, blocking the discharge line so no water is pumped to the surface.

3 Hydrocarbon Discharge Cycle: AIR SUPPLY ON
After the water is gone, the upper check ball sinks in the hydrocarbon and seats, closing off the pump bottom and allowing pump pressure to build. The pressure check valve opens, releasing hydrocarbon into the pump discharge line and up to the surface.

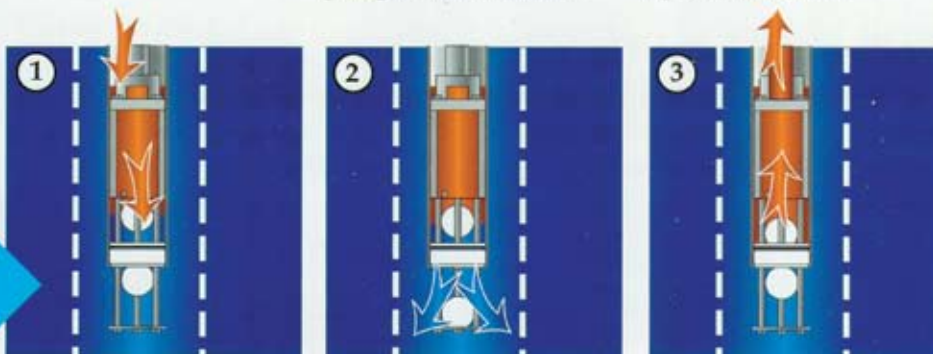

GROUNDWATER REMEDIATION

**Requires external controller*

See C100M

Page 205



Filter Regulator & Well Caps

See page 189-190



Characterise Your Specific Site and Hydrocarbon

The Ferret Test Kit enables you to measure the density and viscosity of your actual floating hydrocarbon layer. These two characteristics determine whether Ferret recovery will be an effective technology at your site and help choose which Ferret system will provide optimum performance. This FREE, do-it-yourself kit comes complete with simple, illustrated instructions. Once you have recorded the results of your hydrocarbon test, QED application specialists will be able to provide expert technical assistance in system design and specification.



QED C100M Digital Controller

The C100M Digital Controller can be used to set pump refill and discharge cycle times for the Programmable Genie®, Ferret® and Pulse Pump®.

The C100M is solar-powered, with unique power-saving circuit design and a 10-day battery backup to allow operation even in northern region winter conditions. It is rated as intrinsically safe in solar mode. An AC power adapter is also included for site conditions which prevent solar charging.

The C100M provides easy-to-use digital control of pump discharge and refill cycles. Its programmable OFF time settings make it convenient to adjust daily pumping rates so that maximum LNAPL flow through the soil can be maintained, to enhance long-term recovery rates.

Optional level switches for the C100M provide an economical means for system shutdown when the collection tank is full and/or the well level drops too low.

Key functions

- GOTO** Allows manual toggling of valve and system ON & OFF cycles. Also enabling and disabling of system
- DATA** Multiscreen key to sequentially display well status, battery status, solar panel voltage, ON/OFF and system valve
- TIME** Allows system counts and time sums and valve time settings



C100M Controller	
Control Type	Solar/Electric/Pneumatic
Dimensions	8.9 cm x 9.3 cm x 8.9 cm
Weight	1.4kg
Enclosure Type	Fiber reinforced thermoplastic NEMA 4X and UL 508
Power	SOLAR: Shatterproof solar panel on enclosure top with backup battery pack with 10-day reserve capacity. CSA* compliance, intrinsically safe, class 1, division 1, group C & D**. Optional power converter plugs into 240 VAC outlet and supplies 3VDC (300 milliamp) to connector plug in enclosure bottom. Not rated intrinsically safe when connected to mains power.
Operating Temperature	-28.9 °C to 65.6 °C
Display	TYPE: LCD display with 16 character alphanumeric, temperature compensated contrast, and power OFF control. WINDOW: Non-glare, double hardened optical acrylic.
Pneumatic Control	TYPE: Latching solenoid with dual port manifold. FITTING: Female 1/4-18 in. NPT brass with nickel plating. PRESSURE: 100 psi (6.9 bar) maximum.
Flow Capacity	Sufficient for single Ferret or single Genie. Contact QED for other requirements

* C100M is rated CSA intrinsically safe when used in solar mode only.
** C100M is NOT rated CSA intrinsically safe when used with 110 VAC power converter.

Ordering Information

- QEDC100M** Digital Controller
- QEDCTRFTFO** Tank Full Shut-Off Kit, to be used in combination with the Model C100(M) Digital Controller
- QED38110** External solar panel and mounting bracket for C100(M). Use of external panel from QED maintains the intrinsically safe rating of the controller.



*only when used in solar mode

QED Tank Full Shutoff

For the ultimate in safety and reliability, QED offers premium, all-pneumatic tank full shutoff controls in wall-mount (301425) and tank-mount (301426) versions. Both of these field-proven controls use fail-safe and redundant mechanisms to ensure that the pumping system is reliably switched off when the LNAPL or DNAPL collection tank is full.

Method of Operation

The TFSO System will cease passing compressed air to downstream systems when the recovery tank is full.

The hoses are colour coded and all the fittings are different so only the proper connections can be made.

The TFSO control includes a two stage filter/regulator. Another filter is provided into the control box for added reliability; this filter also has a visual indicator.



Wall mount shutoff



Tank mount shutoff

Features

- Hoses and tubing are colour coded and all the fittings are different so only the proper connections can be made.
- System operation is simple, straightforward and automatic. Built-in safety features result in operator-free operations even on nights and weekends.
- The TFSO system can be upgraded to monitor additional recovery tanks.
- The TFSO system is small and lightweight and can easily be moved from site-to-site.
- The Wall-Mount TFSO has a three-way valve that allows the operator to shut down the system, exhausting all downstream air without disconnecting hoses or “tripping” the system.
- Rugged construction ensures long system life, even under harsh conditions.
- The entire system is pneumatically powered with no electrical components, thus avoiding sparks in control power and sensing devices.

Ordering Information

QED301425 Wall mount tank full shut off control box

QED301426 Tank full shut off, tank mount control box

C100M Level Switch Overfill Protection Device

When high levels are detected, the C100M will discontinue pump operation and will enter and remain in a “Tank Full” and “System Disable” mode; to resume normal operation, the tank level must be lowered sufficiently to deactivate the switch and the C100M must be manually reset.

Once installed, any disconnections or breaks in the switch cable will also cause a “Tank Full” and “System Disable” response.

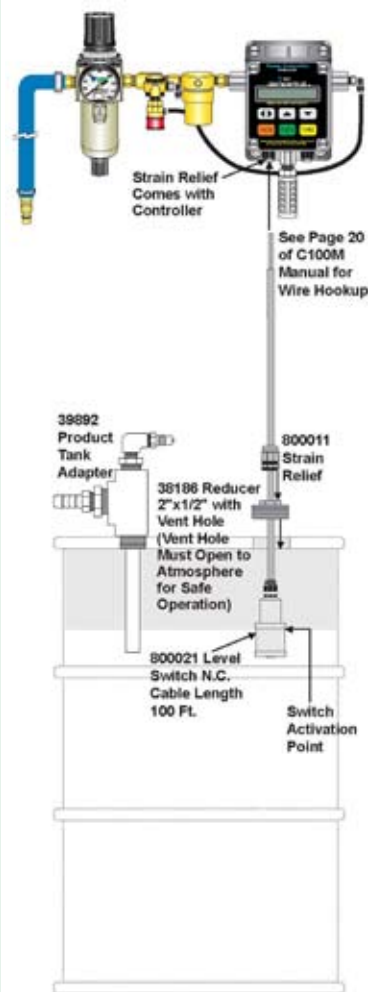

Ordering Information

QEDCTRLSW Downwell Pump Level Switch Kit, to be used in combination with the Model C100M Digital Controller

QEDCTRFTFO Tank Full Shut-Off Kit, to be used in combination with the Model C100M Digital Controller

**For C100M Controller
See page 205**



QED Pulse Pump

Cleanup well conditions can be extremely hostile: powerful solvents, gasoline and fuel oil, strong acids, caustic bases, corrosive chlorides. That's why QED makes the Pulse Pump series (our basic gas displacement pumps) in a variety of proven materials that won't just survive, but will deliver years of trouble-free performance.

Every Pulse Pump model has only two moving parts downwell and high-clearance, self-cleaning ball check valves. This simplicity keeps them working when high solids, viscosity, or chemical attack cause other pumps to clog or breakdown. An external controller is required to control the alternating pressurisation and venting cycles for the pump.

The Pulse Pump design is especially suited for sinking hydrocarbons (DNAPL) recovery, which is often complicated by high viscosity and/or extremely aggressive solvents.

Intrinsically safe Pulse Pump systems are fast and easy to install,

with no electrical connections at the wellhead.

Flow optimisation is simple too; rugged, dependable pumps and controllers (the solar/AC powered C100M and the all-pneumatic L360) deliver reliable operation without needing frequent attention or repair.

Suitable for harsh environments, including the most demanding ground water cleanup, leachate collection and sinking layer recovery applications.

How it works

The Pulse Pump is air-powered and requires an external timer-based controller to control the air cycling OFF and ON to the pump. The external controller provides alternating cycles of venting to allow the pump to fill, and pressurising to discharge the liquid from the pump. The pump fills through the intake check valve during the refill portion of the cycle, while the pump discharge check valve is sealed. When the external controller applies compressed air



to the pump during the discharge cycle, the intake check valve seals and the discharge check valve opens, sending the liquid into the discharge tube to the wellhead. The cycles are then repeated.

The controller options for Pulse Pumps include:

- The all-pneumatic L360, with settable refill and discharge times to match site conditions. The L360 cycle controller can be coupled with the L370 level controller to stop pump operation when liquid levels fall below the set point.
- The C100M electronic controller, which can be powered by its built-in solar panel or the included AC adapter. The C100M provides lots of flexibility in cycle times and settable "Off" periods, as well as economical low liquid level shutoff and tank-full float switches. The AC power source is required for continuous pump operation.

	LP1301	LP1401	LP1001	LP4600
Inlet	Bottom	Bottom	Bottom	Bottom
Outside Diameter	42 mm	32 mm	73 mm	73 mm
Length	51 cm	51 cm	39.4 cm	126 cm
Weight	0.9 Kg	0.7 Kg	1.4 Kg	3.6 Kg
Materials	Stainless steel, PTFE	Brass	PVC	PVC
Fittings: Type/Materials	Compression/SS	Barb/Brass	Compression/Nylon	Barb/Nylon
Sizes: Liquid Discharge	13 mm (1/2in)	13 mm (1/2in)	19 mm (3/4in)	19 mm (3/4in)
Air Supply	9 mm (3/8in)	9 mm (3/8in)	13 mm (1/2in)	13 mm (1/2in)
Pump Stroke	350 mL	300 mL	650 mL	2,000 mL
Operating Pressure Range	40-100 psi	40-100 psi	40-100 psi	40-100 psi
Maximum Lift	70 m	70 m	70 m	70 m
Maximum Flow Rate	7.5 Lpm 10,900 Lpd	6.8 Lpm 9,810 Lpd	11.4 Lpm 16,350 Lpd	28 Lpm 40,800 Lpd
Minimum Submergence	< 30 cm	< 30 cm	< 30 cm	< 30 cm
Density of Pumped Liquid	Any	Any	Any	Any
Cap Sizes	50, 100, 125, 150 and 200 mm	50, 100, 125, 150 and 200 mm	50, 100, 125, 150 and 200 mm	50, 100, 125, 150 and 200 mm

Ordering Information

Select

- Pulse Pump Model
- Material
- Choose controller

For Well Caps
See page 189

Controller to suit
See page 187-188

MODELS TO SUIT 50mm OR 100mm

INTRINSICALLY SAFE

QED Eliminator

The Eliminator is a high capacity bladder pump designed for LNAPL and DNAPL removal in 2in. (50mm) and 4in. (100mm) wells. The Eliminator is also used to handle viscous contaminants, such as crude oil.

Advantages

- 100% air-powered operation.
- No contact between drive air and contaminated fluids.
- Effective skimming of viscous hydrocarbons, such as crude oil.
- Available for 2in. (50mm) and 4in. (100mm) wells or larger.

The Eliminator uses a bladder of PTFE or elastomer to isolate the pump air supply from the pumped liquid. As a result, there is no contact between the drive air and the contaminated fluids inside the bladder and therefore, no emissions of potentially contaminated air.

Eliminator pumps provide reliable top-inlet skimming or bottom-inlet pumping. A wide range of

accessories is available, including “roving” well caps to allow accurate pump inlet positioning, and bladder replacement kits for easy field maintenance.

The Eliminator is powered by compressed air and requires an external timer based controller to control the air cycling ON and OFF to the bladder pump.

Compressed air is supplied directly to the Eliminator via an external controller.

When the bladder is squeezed from the outside by the compressed air, fluid within the bladder is forced out through a check valve at the top of the pump.

Then, when the air pressure around the bladder is exhausted, the bladder expands resuming its original shape. This pulls fluid into the bladder through either the top or bottom inlet, depending on the pump inlet configuration.

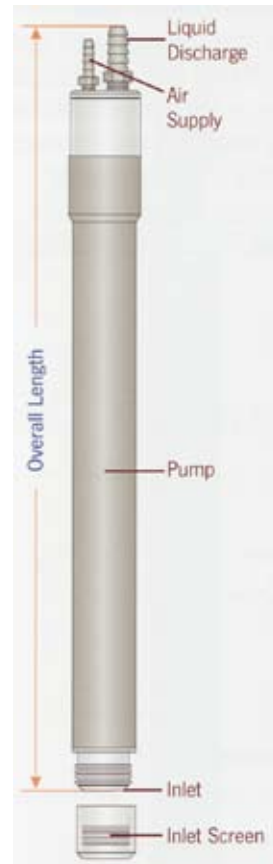

GROUNDWATER REMEDIATION

Flow optimisation is simple too; rugged, dependable pumps and controllers (the solar/AC powered C100M and the all-pneumatic L360) deliver reliable operation without needing frequent attention or repair.

The Eliminator is powered by compressed air and requires an external timer based controller to control the air cycling ON and OFF to the bladder pump.

Compressed air is supplied directly to the Eliminator via an external controller.

When the bladder is squeezed from the outside by the compressed air, fluid within the bladder is forced out through a check valve at the top of the pump.

Then, when the air pressure around the bladder is exhausted, the bladder expands resuming its original shape. This pulls fluid into the bladder through either the top or bottom inlet, depending on the pump inlet configuration.

Model No.	301301	301311	LP1702
Pump Type	Pneumatic bladder	Pneumatic bladder	Pneumatic bladder
Inlet	Top or Bottom	Top or Bottom	Top or Bottom
Outside Diameter	4.3 cm	4.3 cm	7.5cm
Length	145 cm	208 cm	102cm
Weight	1.6 Kg	1.6 Kg	5.2 kg
Material	Stainless Steel, brass, Viton®, Teflon®, urethane bladder	Stainless Steel, brass, Viton®, Teflon®, urethane bladder	Stainless Steel, Q-Tal, PTFE bladder, Viton® o-rings
Fittings	Brass quick-connects	Brass quick-connects	Brass barbs
Fitting Sizes	Liquid Discharge: 1/4 in. (.64 mm) Air Supply: 1/4 in. (.64 mm)	Liquid Discharge: 1/4 in. (.64 mm) Air Supply: 1/4 in. (.64 mm)	Liquid Discharge: 3/4 in. (19 mm) Air Supply: 1/2 in. (13 mm)
Volume per Cycle	125 mL	245 mL	2000ml
Operating Pressure	40-100 psi (2.8-6.9 bar)	40-100 psi (2.8-6.9 bar)	40-100 psi (2.8-6.9 bar)
Maximum Lift	46 m	46 m	70 m
Maximum Flow Rate	.51 Lpm	.983 Lpm	23 Lpm
Minimum Submergence	7.6 cm	7.6 cm	45.6 cm
Density of Pumped Liquid	Any	Any	Any

**Requires external controller
See C100M page 205
or L360 page 188*



**QED Iron Horse
Piston Pump**

Iron Horse pumps are designed to provide dependable pumping in applications that benefit from the special capabilities of piston pumps, such as slant wells, sites requiring no drive air with the pumped fluids, deeper wells and drawdown to extremely low levels.

Advantages

- Extended duty between service compared to other piston pump designs.
- Simple driver with reliable, built-in reciprocation mechanism.
- Seal-less, stainless steel pump piston.
- Serviceable check valves and drive cylinder.
- Extreme low draw-down capability.
- Isolates driver air from pumped liquid.
- Slant-well and horizontal applications .



Iron Horse pumps are air-powered and use a reciprocating air cylinder at the wellhead to drive a piston down in the well, connected by a flexible fiberglass rod. Each piston stroke lifts a known amount of liquid and provides positive suction at the inlet.

Piston pumps can be installed in wells and risers at any angle, including horizontal. Unlike older piston pump designs used in landfills and remediation sites, Iron Horse pumps are designed from the start for durability and serviceability to greatly reduce maintenance frequency and costs.

In comparative testing, Iron Horse has demonstrated critical component life many times that of older piston pump designs. The simplicity and strength advantages of the Iron Horse are visible even from first appearances. QED's extensive engineering experience and resources have delivered the first piston pump good enough to carry the QED name.

	IH 125 System (1-1/4" Drop Pipe)	IH 200 System (2" Drop Pipe)
Max. Flow Rate	7.5 lpm	18.9 lpm
Approx. Pump Volume/Cycle	0.170 L	0.454 L
Max. Cycle Rate	40 cpm	40 cpm
Max. Depth*	121.9 m	54.8 m
Min. Liquid Pumping Level Above Bottom	Standard Screen: 30.5cm Short Screen: 15.2cm)	Standard Screen: 30.5cm Short Screen: 15.2cm
Max. Air Pressure	120 psi (8.4 kg/cm2)	120 psi (8.4 kg/cm2)
Min. Well Casing Inside Diameter	101mm	127mm
Driver Assembly	Weight: 9.97 Kg Length: 1.27m without gauge Max. Diameter: 101mm Drive Piston Diameter: 50mm	Weight: 9.97 Kg Length: 1.27m without gauge Max. Diameter: 101mm Drive Piston Diameter: 50mm
Downwell Pump Assembly	Piston: Weight: 0.68 Kg Length: 27.9 cm Diameter: 2.69 cm Pump Cylinder Assembly: Weight: 2.27 Kg Length: 1.47 m Outside Diameter: 5.72 cm	Piston: Weight: 2.94 Kg Length: 45.7 cm Diameter: 4.44 cm Pump Cylinder Assembly: Weight: 3.85 Kg Length: 1.62 m Outside Diameter: 8.51 cm
Drive Rod	1/2 in (12.7mm) diameter, 3/8 in (9.5mm) pultruded epoxy and glass fiber with protected anti-abrasion coating	
Drop Pipe	1-1/4 in (3.175cm) CPVC Schedule 80, 10 ft (3.04m) sections, threaded connections	

E-Z Tray®
Low Profile Air Stripper
 Removable tray high-efficiency air
 stripper for VOC removal

The E-Z Tray® Air Stripper is a low-profile, stainless steel air stripper used to remove volatile organic compounds (VOC) from groundwater. The exclusive design of the E-Z Tray stripper results in VOC removal rates up to 99%.

Advantages

- Single person cleaning.
- Easy accessibility .
- Space and construction size savings.
- High efficiency VOC removal - up to 99% .

The E-Z Tray air stripper uses lightweight, front slideout trays. This unique feature provides many advantages, such as one man operation and cleaning and installation is small areas.

E-Z Tray air strippers are available in configurations with 4 or 6 trays, with maximum flow rates from 4-100 Lpm to 4-946 Lpm.

**High Capacity Process
 Air Strippers**

New, larger models of E-Z Tray air strippers increase the flow rate capability of the company's air stripper lineup four-fold, from a maximum 4-100 LPM to 4-3,784 LPM.

Combined with the easier maintenance and smaller footprint of QED's sliding tray air strippers, this has led to their becoming the preferred choice for major remediation and process stream projects in the US and abroad.

These air strippers are engineered to serve in larger, process-type projects involving multiple treatment stages, where they are an effective component of large-scale water or wastewater processes in manufacturing, refining, chemical processing and other industries. They can act as a pre-treatment stage for other process elements, such as large aerobic biotreatment units, removing VOCs at much lower airflow rates to reduce the costs of off-gas treatment.



ONLINE AIR STRIPPERS MODELER

Learn how the QED online Air Stripper modeler can assist you in selecting the most efficient air stripping package for your groundwater cleanup project. See www.qedenv.com

How it works

As contaminated groundwater enters through the top of the air stripper, millions of air bubbles are forced by the blower pressure up through the perforated trays, vigorously aerating the water to a froth and removing volatile contaminants (VOC) as gravity pulls the water down through each tray.

This simple, revolutionary technology delivers up to 99% VOC removal, while the low maintenance and easy access cut O&M costs dramatically.

E-Z Stacker® Low Profile Air Stripper Stackable high-efficiency air stripper for VOC removal

The E-Z Stacker® Air Stripper (U.S. Patent Number 5,518,688) is a low profile air stripper used to remove volatile organic compounds (VOC) from groundwater. The exclusive design of the E-Z Stacker stripper results in VOC removal rates up to 99%.

Advantages

- Cylindrical shape provides consistent tray-to-tray contact with no loose or weak points from corners or edges.
- 360 degree lockdown ring, made of solid 2 x 2 x 1/4" steel angle stock, applies even pressure to the whole circumference of the complete stack.
- Recessed tray bottom prevents contact between the water and the gaskets.
- Heavy-duty gaskets are captured on both inboard and outboard edges to eliminate creeping.
- Continuous moulded-in bead provides optimum gasket compression.
- Unlike tedious, potentially weak tray-to-tray latches, the whole stack ties down securely with just four easy access connections.

The unique E-Z Stacker configuration consists of a series of integrally-molded shell/tray modules. The multiple sieve tray design uses forced-draft air bubble generation to provide rapid, effective VOC removal (up to 99%).

Every element of the heavy-duty HDPE construction has been engineered for durable, reliable performance with a multi-step positive seal against leakage.

The E-Z Stacker air strippers are available in configurations with 4 or 6 trays, with maximum flow rates from 4 - 151 LPM.

The innovative design of E-Z Stacker® Air Strippers delivers many advantages to environmental consultants, remediation contractors and end-users.

E-Z Stacker models are sized and priced to be the most economical choice for many low to moderate flow cleanup applications (up to 40 GPM). Low capital expense and low O&M requirements make the difference.

Easy disassembly cuts cleaning costs

Disassembly for routine cleaning is a quick, simple, one-person job. The whole stack (4 or 6 trays) can be taken apart by releasing just four connections. Trays have no loose parts when disassembled, and cannot be reassembled incorrectly.

Easy-access fittings allow units to be placed in corners or other tight spaces. Two sizes are available in 4 or 6 tray versions, for maximum flow ranges from 1-25 GPM.

ONLINE AIR STRIPPERS MODELER

Learn how the QED online Air Stripper modeler can assist you in selecting the most efficient air stripping package for your groundwater cleanup project. See www.qedenv.com

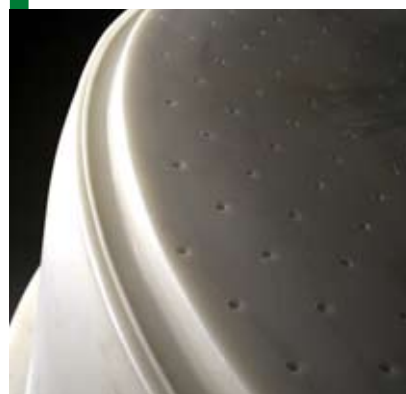

AutoTracker® Vacuum Extraction Inlet

How to Supercharge Your Dual-Phase Extraction Project

The patented AutoTracker™ Floating Extraction Inlet optimises dual-phase extraction and bio-slurping system performance by assuring proper air-to-water ratios even as water levels change.

Groundwater fluctuations can cause severe disruptions for dual-phase extraction systems using a fixed entrainment drop pipe.

When the water table falls below the elevation of a fixed extraction inlet, groundwater recovery ceases and treatment efficiency decreases. When the water level rises above the end of a fixed inlet, vapor recovery becomes impossible. AutoTracker Floating Extraction Inlets eliminate these common causes of system shutdowns and missed recovery goals.

The Problems with Conventional Fixed Drop Pipe Systems are:

- Conventional fixed drop pipe DPE system depends on precise positioning
- Small changes in well liquid level can shut the operation down
- AutoTracker eliminates these problems

How it works

Dual-phase extraction (DPE) is the simultaneous recovery of gases and liquids from the same remediation well without the use of pumps and controls at each well. High velocity vapor flow entrains the water and allows it to be extracted from depths beyond the static suction capability of the vacuum source.

With the right site conditions and with the gas and liquid inlets properly positioned, this can be a highly effective method of contaminant recovery from both the saturated and vadose zones. However, installation of systems with a fixed entrainment tube can be complicated and time-consuming, and changing liquid levels in the remediation well can cause costly downtime and necessitate frequent site visits for maintenance, increasing both O&M and life cycle costs.

AutoTracker Floating Extraction Inlets from QED will deliver optimum performance from your DPE system by continuously and automatically reacting to changes in well level, positioning gas and liquid inlets properly and allowing the system to function at peak efficiency at all times.

Case studies with AutoTracker show that you can:

- Cut O&M costs by 20% instantly
- Clean up your site 33% faster
- Save 1/2 of the life cycle cost.

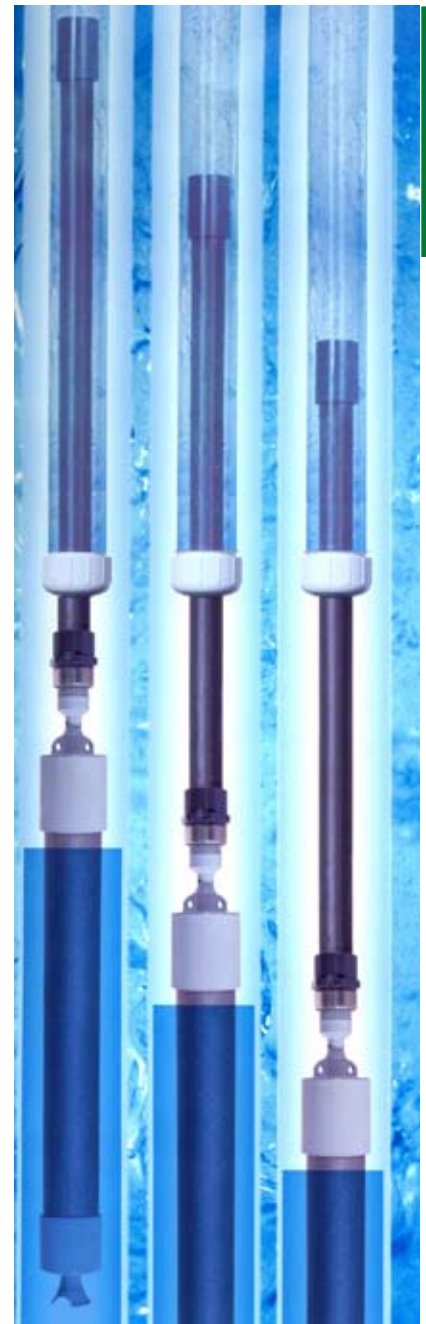

Activated Carbon Filtration Drums

Activated Carbon has a variety of uses in remediating contaminated air, liquid and water. Carbon filters are used for air and liquid purification covering the entire spectrum of applications and flow-rates.

Drums of carbon can be expected to adsorb up to 10-15% of their carbon mass with hydrocarbon contaminants and up to 30% for chlorinated compounds. This simple rule will allow you to estimate how long a drum of carbon will last at your site. Simply divide your ppm concentration into the weight of the carbon to get the volume the drums can process. Maximum influent concentrations for liquid streams are 40 ppm. Higher concentrations cause premature blocking of the carbon.

Water Pollution

The water scrub units are filled with high quality activated carbon. They are designed for the efficient purification of your liquid waste or process stream. In service, the units have a proven ability to remove organic contaminants to non-detectable levels.

Air Pollution

The vapour scrub units are designed for efficient purification of vapour waste or process stream. Can remove organic contaminants to non-detectable levels.



Specifications

For Water Pollution (HAYCDW)

Liquid Flow Rate

Chlorinated contaminants 30 lpm

Hydrocarbon Contaminants 20 lpm

Max. Pressure 25 kPa (15psi)

Connection Port Sizes 50mm female thd

Shipping Weight 100kg

Contains 90kg carbon material

For Air Pollution (HAYCDV)

Air Flow Rate 2.5m³/min

Max. Pressure 100kPa (15psi)

Connection Port Sizes 50mm

Shipping Weight 100kg

Contains 90kg carbon material

Ordering Information

HAYCDW Carbon Filter Drum for Water,
210 Litre

HAYCDV Carbon Filter Drum for Air/
Vapour, 210 Litre

ThermoFisher
S C I E N T I F I C

Australia: For customer service, call 1300-735-295

Visit us online at: www.thermofisher.com.au

New Zealand: For customer service, call 0800-933-966

Visit us online at: www.thermofisher.co.nz

©2011 Thermo Fisher Scientific Inc. All rights reserved.